

E Series

Commercial fully automatic coffee machine

Model E20/E20B/E20T

Original version



Content

1 For your safety	01
1.1 Proper use	01
1.2 Prerequisites for using the coffee machine	01
1.3 Explanation of safety symbols	02
1.4 General safety concerns when using the coffee machine	02
2 Description of machine	05
2.1 Machine overview	05
2.2 Screen interface	06
2.3 Scope of delivery	09
2.4 Technical data	10
3 Installation	11
3.1 Installation tips	11
3.2 Dimensions	11
3.3 Installation location	12
3.4 Electrical connection	13
3.5 Water supply connection	13
4 Start-up for the first time	14
4.1 Material filling	14
4.2 Initially start-up program setting	14
5 Operation	15
5.1 Coffee beans filling	15
5.2 Water tank filling	15
5.3 Switch on the machine	16
5.4 Beverage preparation	16
5.5 Grinding coarseness setting	18
6 Program setting	18
6.1 Access to the menu	18

Content

6.2 Program setting menu tree	19
6.3 Maintenance	19
6.4 Beverage	21
6.5 System	25
6.6 Operation panel	27
6.7 User	31
6.8 Language	32
6.9 Statistics	32
6.10 Help	33

7 Cleaning and maintenance **33**

7.1 Cleaning intervals overview	33
7.2 Parts preparation	34
7.3 Daily cleaning	34
7.4 Weekly cleaning	36
7.5 Brew unit cleaning if presents	38
7.6 Milk system cleaning if presents	38
7.7 Descaling if presents	39

8 Messages and explanation **40**

8.1 Operational messages	40
8.2 Error message	41

9 Decommissioning **41**

9.1 Prepare for decommissioning	41
9.2 Short-term decommissioning (within one month)	42
9.3 Long-term decommissioning (over one month)	42

10 Transport and storage **42**

10.1 Transport	42
10.2 Storage	43
10.3 Recommissioning after prolonged periods of storage or non-use	43

11 Disposal **43**

1. For your safety

1.1 Proper use

1.1.1 Coffee machine

1. The machines are commercial machines for preparing drinks and are intended for use food services, offices, hotel, convenience store and other similar environments.
2. The machines are designed to process coffee beans and fresh milk.
3. The machines intended for operation indoors but is not suitable for use outdoors.

1.2 Prerequisites for using the coffee machine

1. The machines are intended for use only by trained personnel.
2. Do not operate the machines or add-on units until you have completely read and understood relative description.
3. Self-service coffee machines must always be monitored to protect the users.
4. Do not use the machines or add-on units if you are not familiar with the various functions.
5. Do not use the machines unless the machine or the add-on units have been cleaned or filled as intended.
6. Children under the age of 8 are not permitted to use the machines and the add-on units. After learning safe ways to use the machine and understanding the risks result from incorrect ways. Children over the age of 8 and persons with reduced physical, sensory, or mental capabilities or with inexperienced or lack knowledge in how to use the machine are permitted to use the machines under the continuous supervision.
7. Do not install the coffee machine in the area of water jet.
8. Clean the coffee machine at least once a day and more frequently if necessary, and only use cleaning tablet, descaling powder supplied by Kalerm. See chapter 7 or Cleaning&Descaling manual for the details.
9. See the following concerns carefully and operate according to the display during maintenance. See chapter 7 or Cleaning&Descaling manual for the details.

1.3 Explanation of safety symbols

Observation of these safety instructions is imperative to ensure personal safety and the intactness of machine. Symbols and signal words indicate the level of hazards as follows:



WARNING

WARNING indicates a potential danger, if not avoided, will may result in death or moderate injury.



CAUTION

CAUTION indicates a hazardous situation which, if not avoided, could result in minor or moderate injury.



NOTICE

NOTICE directs your attention to the risk of damage to machinery.

1.4 General safety concerns when using the coffee machine

Improper use of coffee machine can lead to potential danger during operation. To avoid personal injury and health hazard, please note following tips when using the coffee machine.



WARNING

Health hazard due to electrical shock

If the supply cord is damaged, it must be replaced by a special cord or assembly available from the manufacturer or its service agent.

1. Damaged power cords, lines or plug connections can lead to electrocution.
2. Do not connect any damaged power cords, lines or plug connections to the power supply.
3. Ensure that the machine and the power cord are not near any hot surfaces such as gas or electric stoves or ovens.
4. Ensure that the power cord is not pinched and does not chafe on sharp edges.
5. Immerse power plug in water or other liquids are not allowed, as well as pouring water or other liquids on the power plug. Power plug must be dry.
6. Repairs or servicing improperly performed on electrical systems can lead to electrocution.
7. Have servicing work carried out by authorized persons with corresponding qualifications only.

**WARNING****Danger of suffocation**

1. Plastic packaging materials could cause children to suffocate.
2. Ensure that children and persons with reduced physical, sensory, or mental capabilities have no access to plastic packaging materials.

**CAUTION****Risk of scalding**

1. Hot liquids during cleaning can lead to scalding. Keep hands away from the spouts during this process.
2. Do not put anything on the drip grid.
3. Use only suitable drinking vessels.
4. Always be careful with hot drinks.
5. IN CASE OF SCALDING: Immediately cool the affected area and consult a doctor, depending on the severity of the injury.

**CAUTION****Risk of injury**

1. If objects drop into the grinder, splinters may be ejected, leading to injury.
2. Never put any objects into the grinder.

**CAUTION****Cutting injuries/crushing**

1. Active components in the interior of coffee machine will hurt fingers or hands.
2. Remember to switch off coffee machine and unplug the power cord before remove grinder or reach into brew module.



CAUTION

Irritation from cleaning agent

1. Cleaning tablets and descaling agent can lead to irritations.
2. Observe the hazard warnings on the label of the respective cleaner.
3. Avoid contact with your eyes and skin.
4. Wash your hands after contact with cleaning agent. Consult a doctor if necessary.
5. Cleaning agent must not find their way into drinks.



CAUTION

Health hazard due to germ formation

1. Inadequate cleaning can result in food residues accumulating in the machine thereby contaminating products.
2. Do not use the machine unless it has been cleaned according to the instructions.
3. Clean the machine daily in accordance with the instructions.
4. Inform operating personnel of the necessary cleaning measures.
5. If the machine is not used for extended periods, residue may accumulate. cleaning the machine before using.
6. Using a water filter for too long can lead to the build-up of algae. Replace the water filter when prompted to do so by the machine.
7. Coffee beans, and powder must in the expiration date.



CAUTION

Risk of mechanical injury

1. The appliance has to be placed in a horizontal position.
2. If the machine has not been drained and emptied completely, it must not be stored at sub-zero temperatures. Put the machine in the temperature about of 20°C for 2-4 hours if freezing occurs.

2. Description of machine

2.1 Machine overview

The E20 series coffee machines are available with numerous options. A sample configuration is illustrated here. Please note that your coffee machine may look different from the configuration shown here.



Rear of machine

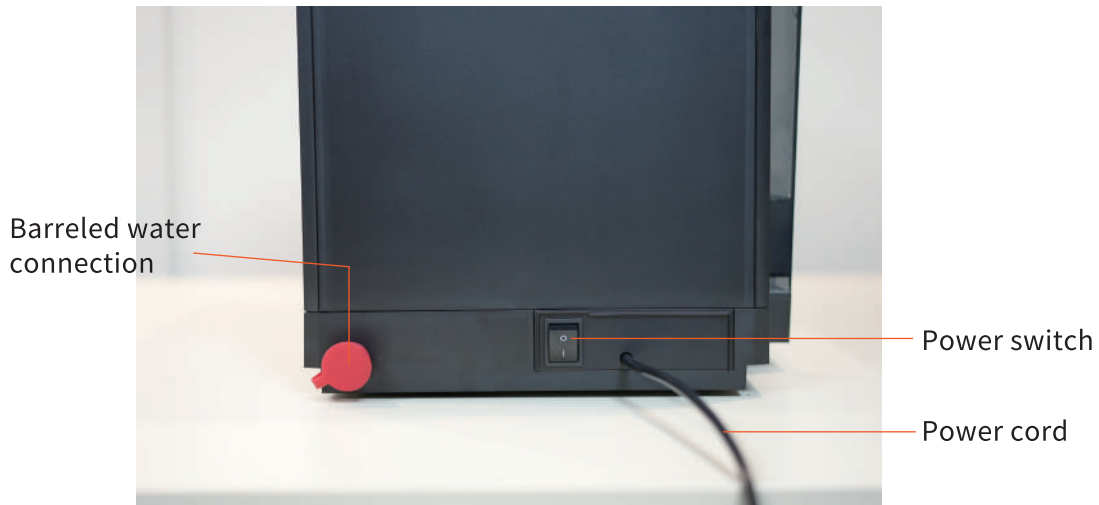

2.2 Screen interface

E20 series are available with three kinds of user interfaces-standard ,self-service and professional to satisfy the needs of different scenarios. See page 23 for changing the themes.

2.2.1 Standard interface



Touching 'logo' icon can start up member function setting

Standard interface is designed to use for non-professional operator or professional personnel. Member function can be performed on the upper right of screen.

2.2.2 Self-service interface

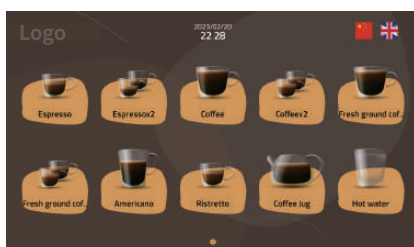

Select language quickly here (four different languages are available)













Specially designed to use in self-service scenarios breakfast store and hotel. User can select language from upper-right corner of screen quickly without access to the menu.

2.2.3 Professional interface







Generally used in commercial scenarios, and the machine needs to assign with professional operating personnel to use. Continue to order is available in this interface.

2.2.4 Symbols on the screen





Symbol	Name	Description
	Member	Access to membership setting
Logo	Logo	Access to the menu setting
	scroller	Tips for drinking pages and current page
	Add	Add drinks
	Close	Close current page
	Alert	View the exception message
	Boiler temperature	Display boiler temperature
	Brew unit position	Display operation status of current brew unit
	Error message	Display error message appeared on the current machine
	Water-flow	Display current water-flow velocity, unit: ml/s
	Inactive	Drink is 'inactive' and cannot be prepared
	Thermoblock temperature	Display thermoblock temperature
	Operation steps	Operation steps for currently initialization of system

2.2.5 Symbols in the menu setting

Symbol	Name	Description
	Exit	Return to main page. Need to input PIN code to access to the menu again
	Main page	Return to main page. Do not need to input PIN code to access to the menu again
	Selection	The item is selected or activated
	Edit	Edit this item is permitted

2.3 Scope of delivery

The scope of delivery may vary, depending on the device configuration

Part	Picture	Quantity
Key		1
User manual		1
Tap water connection pipe (E20T)		1
Tap water connector (E20T)		2
Barreled water pipe (E20B)		1

2.4 Technical data

Screen dimensions	7 Inches
Water tank capacity	4 liters
Drip tray capacity	1.6 liters
Grounds container capacity	30pieces
Coffee spout height	80-160mm
Permissible Water pressure	0.5~0.6 Mpa
Bean hopper capacity	550g
Power supply type	220-240V 50Hz
Power rating	1500W
Machine Dimensions	526mmx349mmx473mm
Net weight	15kg
Noise value	55-70db



Depending on the model and sales area of the machine, IOT function is optional. Contact customer service for the details.

Radio frequency and parameters			
GSM	nonsupport	supportGPRS: <input type="checkbox"/> Yes <input checked="" type="checkbox"/> No supportEDGE: <input type="checkbox"/> Yes <input checked="" type="checkbox"/> No	
CDMA	nonsupport	cdma2000	nonsupport
WCDMA	nonsupport		
TD-SCDMA	nonsupport		
TD-LTE	<input checked="" type="checkbox"/> B38 <input checked="" type="checkbox"/> B40		
LTE FDD	<input checked="" type="checkbox"/> B1 <input checked="" type="checkbox"/> B3 <input checked="" type="checkbox"/> B7 <input checked="" type="checkbox"/> B8 <input checked="" type="checkbox"/> B20		
5G	nonsupport		
GPS	support		
WLAN	<input checked="" type="checkbox"/> 2.4GHz <input checked="" type="checkbox"/> 5.1GHz <input checked="" type="checkbox"/> 5.8GHz		
Bluetooth	<input checked="" type="checkbox"/> 2.4GHz <input checked="" type="checkbox"/> BR <input checked="" type="checkbox"/> EDR <input checked="" type="checkbox"/> LE (<input checked="" type="checkbox"/> 4.0 <input type="checkbox"/> 5.0)		
WLAN section details			
Support system	2.4GHz: <input checked="" type="checkbox"/> 802.11b <input checked="" type="checkbox"/> 802.11g <input checked="" type="checkbox"/> 802.11n <input checked="" type="checkbox"/> 802.11ax		
	5.1GHz: <input checked="" type="checkbox"/> 802.11a <input checked="" type="checkbox"/> 802.11n <input checked="" type="checkbox"/> 802.11ac <input checked="" type="checkbox"/> 802.11ax		
	5.8GHz: <input checked="" type="checkbox"/> 802.11a <input checked="" type="checkbox"/> 802.11n <input checked="" type="checkbox"/> 802.11ac <input checked="" type="checkbox"/> 802.11ax		
occupied bandwidth	2.4GHz: <input checked="" type="checkbox"/> 20M <input checked="" type="checkbox"/> 40M		
	5.1GHz: <input checked="" type="checkbox"/> 20M <input checked="" type="checkbox"/> 40M <input checked="" type="checkbox"/> 80M <input type="checkbox"/> 160M		
	5.8GHz: <input checked="" type="checkbox"/> 20M <input checked="" type="checkbox"/> 40M <input checked="" type="checkbox"/> 80M		



The radio technical parameters and frequency range of the machine are only matched with the IoT configuration. Contact customer service for the details any questions

The radio technical parameters and frequency range of this equipment are as follows

Media Types	Commercial fully automatic coffee machine		
Model	E20,E20B,E20T		
Modulation Mode	TD-LTE : QPSK/16QAM BT : GFSK, $\pi/4$ -DQPSK, 8-DPSK WLAN: DBPSK/DQPSK/CCK/ BPSK/QPSK/16QAM/64QAM		
TECHNICAL PARAMETER	Frequency range	Occupied bandwidth	Transmitted power
Targeted value	TD-LTE : Band38: 2570-2620MHz Band 40: 2300-2400MHz BT: 2.400-2.4835GHz 2.402-2.4800GHz WLAN: 2.400-2.4835GHz	TD-LTE: \leq 20/10MHz BT: \leq 2MHz WLAN: \leq 20MHz \leq 40MHz	TD-LTE: 23dBm \pm 2.7dB BT: \leq 20dBm(EIRP) WLAN: \leq 20dBm(EIRP)

3. Installation

3.1 Installation tips

1. Only an instructed service-engineer may install the machine.
2. The manufacturer is not liable for injuries caused by an improper mounting of the unit.
3. Installation must use original accessory.
4. Installation personnel will carry out the initial commissioning process for your coffee machine and walk you through the basic functions.



Please contact customer service for further support if you have any questions

3.2 Dimensions

Dimension unit: millimeter

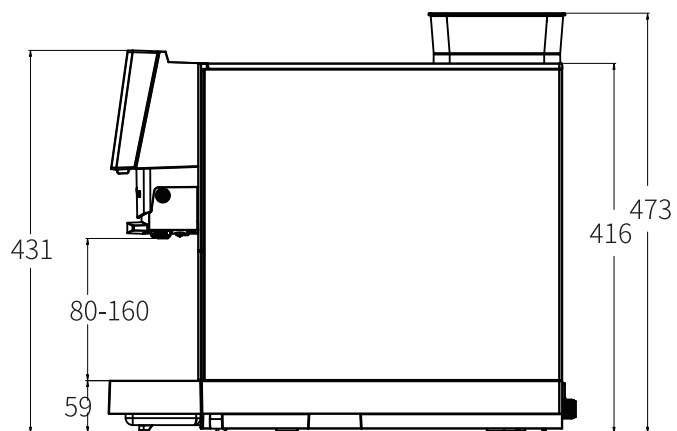
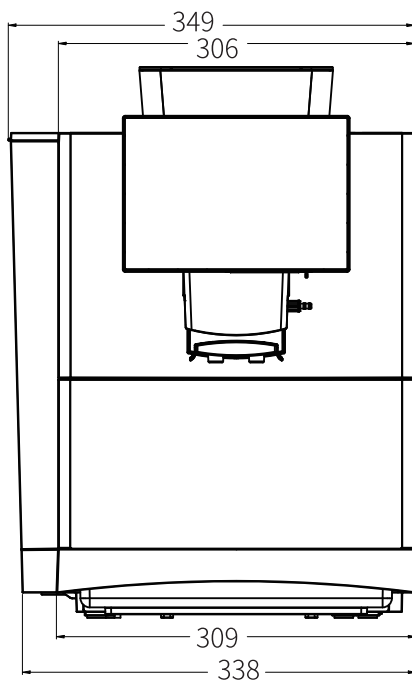
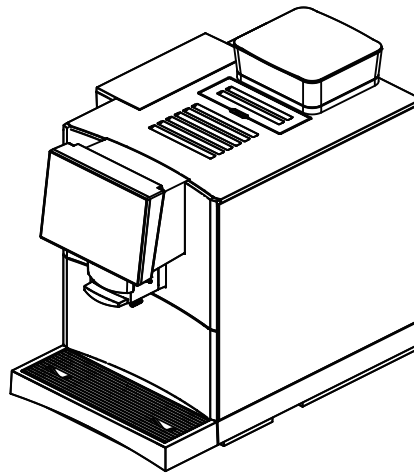
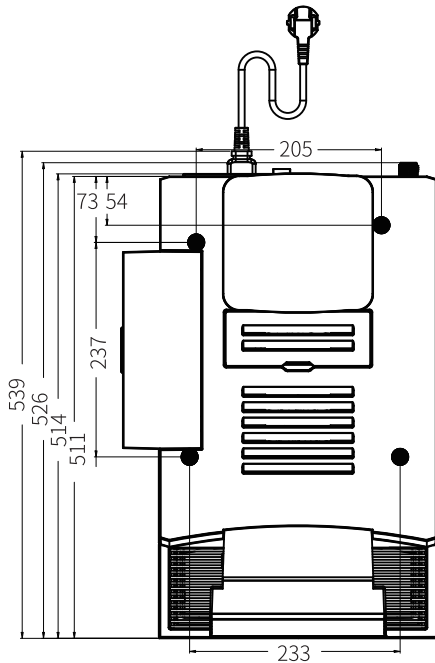

3.3 Installation location

1. The installation location must be dry and protected against water spray
2. Some condensate, water can always be discharged from a coffee machine
3. Do not use the coffee machine outdoors.
4. The machine has to be installed on a solid, level and heat-resistant base.
5. The surrounding temperature must be between 5°C~35°C.

3.4 Electrical connection

1. The mains connection must correspond with the voltage, amperage and frequency indicated on the machine label.
Installation of wrong or improper electric plugs can cause short circuit resulting in fire. The plug has to be selected and installed by qualified service personnel only.
2. The machines are electrically safe only when properly earthed as described in the current electrical safety specifications. Check for compliance and, when in doubt, have the wiring thoroughly inspected by skilled personnel.
3. The manufacturer does not take any responsibility for any damage caused by incorrect earthing or improper use of power supply .
4. No action needed from users to shift the product between 50 and 60Hz, product can adapt itself for both 50 and 60 Hz.

3.5 Water supply connection

Tank water supply, fixed water supply and barreled water supply are available for the E20T series. Tank water supply and barreled water supply are available for E20B. Tank water supply is available for E20. Default water supply is water tank.

3.5.1 Water quality

Total hardness:	4 – 8 dH GH
	70 – 140 ppm (mg/l)
Carbonate hardness	3–6 dH KH / 50–105 ppm (mg/l)
Acid content/pH value	6.5–7.5 pH
Chlorine content	< 25 mg/l
TDS	30 – 150 ppm (mg/l)
electric conductivity	50–200 μ S/cm (microsiemens)
Iron content	< 0.3 mg/l

To guarantee the required water quality, a water filter system needs to be installed

3.5.2 Tap water connection

The distance between the machine and the water connection should not be more than 1 meter (to connect the appliance, use the supplied original hose only). The water pressure must be between 2-6bar. If the water pressure is more than 6 bar, a pressure reducing valve must be installed.

3.5.3 Barreled water supply connection

Barreled water supply connection needs to use accessories supplied with factory. Please contact customer service for help if need to use barreled water function.

3.5.4 water filter installation

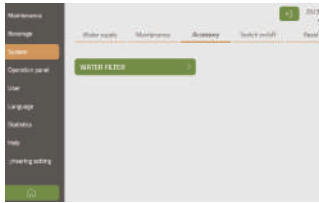

1. Select System-Accessory-Water filter



2. Select installation/replacement and internal water filter, input water capacity based on suitable level, then touch complete

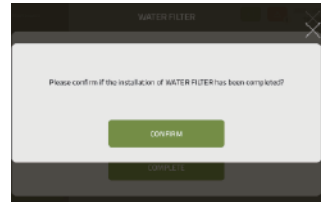

3. Touch confirm

4. Start-up for the first time

4.1 Material filling

Adding material into the machine. See page 14 for specific operation



Please use water tank supply for first time use

4.2 Initially start-up program setting

After switch on the machine initially, access to the setting of start-up program for the first time is available. Specific process as follows:



1. Plug the mains cable for the coffee machine into an electrical outlet and press the powerswitch

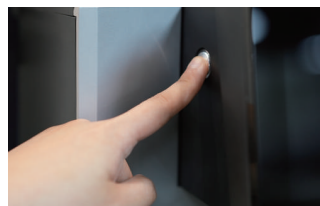

2. Press the screen power button

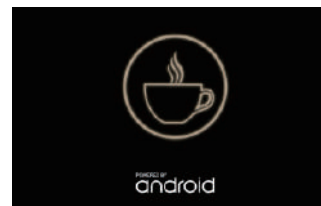

3. Screen is on

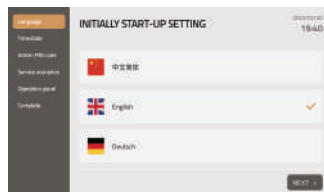

4. Select language



Set time and date



6. Set PIN code

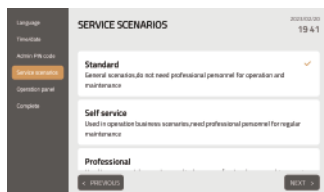

7. Select screen interface

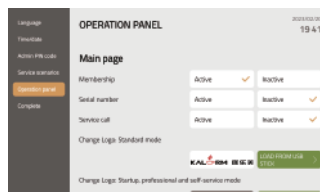

8. Set the panel display

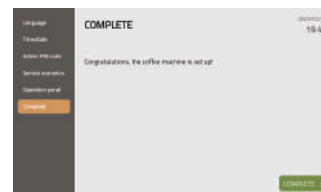

9. Click 'complete' to finish the setting

5. Operation

5.1 Coffee beans filling



1. Lift bean hopper lid

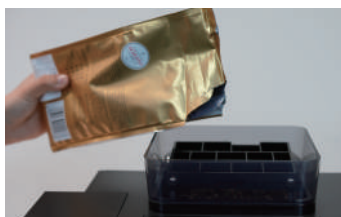

2. Add coffee beans



3. Attach lid



Never put any objects into the bean hopper or grinder. Otherwise, splinters may be ejected, leading to injury.



1. Do not pour ground coffee into bean hopper
2. Do not pour any liquids into bean hopper

5.2 Water tank filling



1. Pull out the water tank



2. Fill water tank with drinking water



3. Attach water tank (Ensure water tank is installed in position)



1. Surface of water can not over the maximum marking identification of water tank
2. Do not fill the water tank with hot water, which may damage machine.

5.3 Switch on the machine

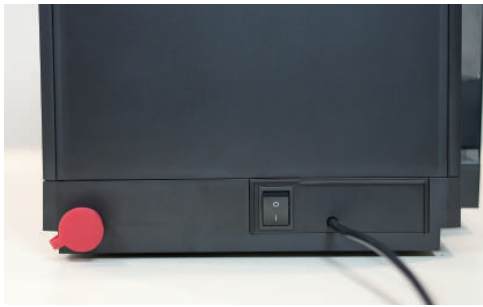

Process of switch on the machine please see page 14 start-up for the first time/start-up program.

5.4 Beverage preparation

5.4.1 Beverage preparation in standard interface



1. Place an appropriate cup under the beverage outlet

2. Touch beverage icon

3. Beverage in preparation

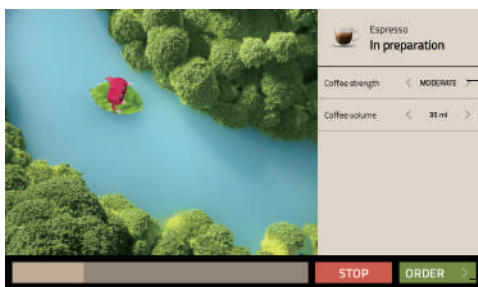

Touch '<' '>' can change parameter during the beverage preparation

Touch '**Order**' to select another desired beverage

Process bar

Cancel beverage preparation by touching '**Stop**'

5.4.2 Beverage preparation in 'self-service' interface



1. Place an appropriate cup under the beverage outlet



2. Touch beverage icon

3. Beverage in preparation

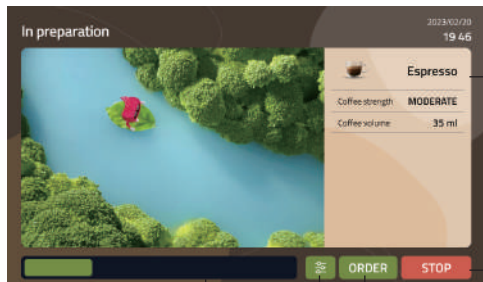

Process bar

Touch '<' '>' can change parameter during the beverage preparation

Cancel beverage preparation by touching 'Stop'



Touch 'Order' to select another desired beverage



Change parameter during the beverage preparation

5.4.3 Beverage preparation in 'professional' interface



1. Place an appropriate cup under the beverage outlet



2. Touch latte icon



3. Beverage in preparation

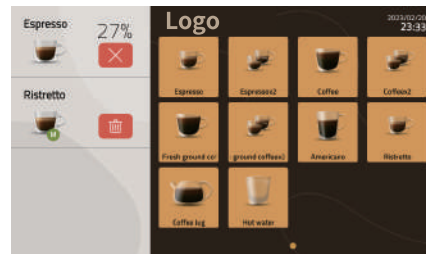

4. Queuing function can be used when beverage in preparation Touch Americano beverage icon when preparing Ristretto, Americano will be displayed in the queuing list as below.

5.5 Grinding coarseness setting

Grinding coarseness could be calibrated by using calibration program. Contact your customer service for the help.

6. Program setting

6.1 Access to the menu



1. Touch logo icon on the upper-left corner

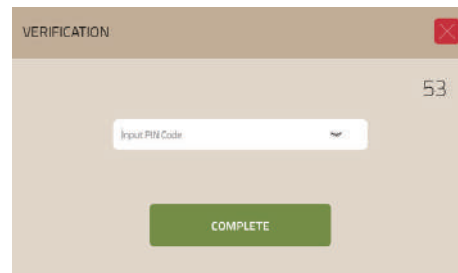

2. Input PIN code and touch complete

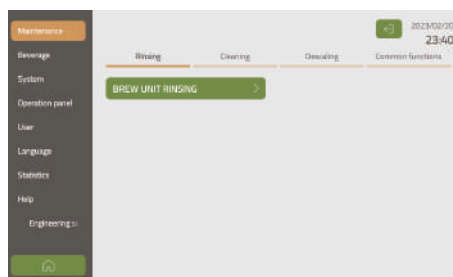

3. Select the target menu



- 1. PIN codes can be set in the start-up program for the first time. If PIN codes are not be set, the default codes are empty.
- 2. Enter different PIN codes can obtain different menu rights. Specific setting of PIN codes ' rights assignment can be checked and changed in the menu of System setting/user/ maintenance rights.

6.2 Program setting menu tree

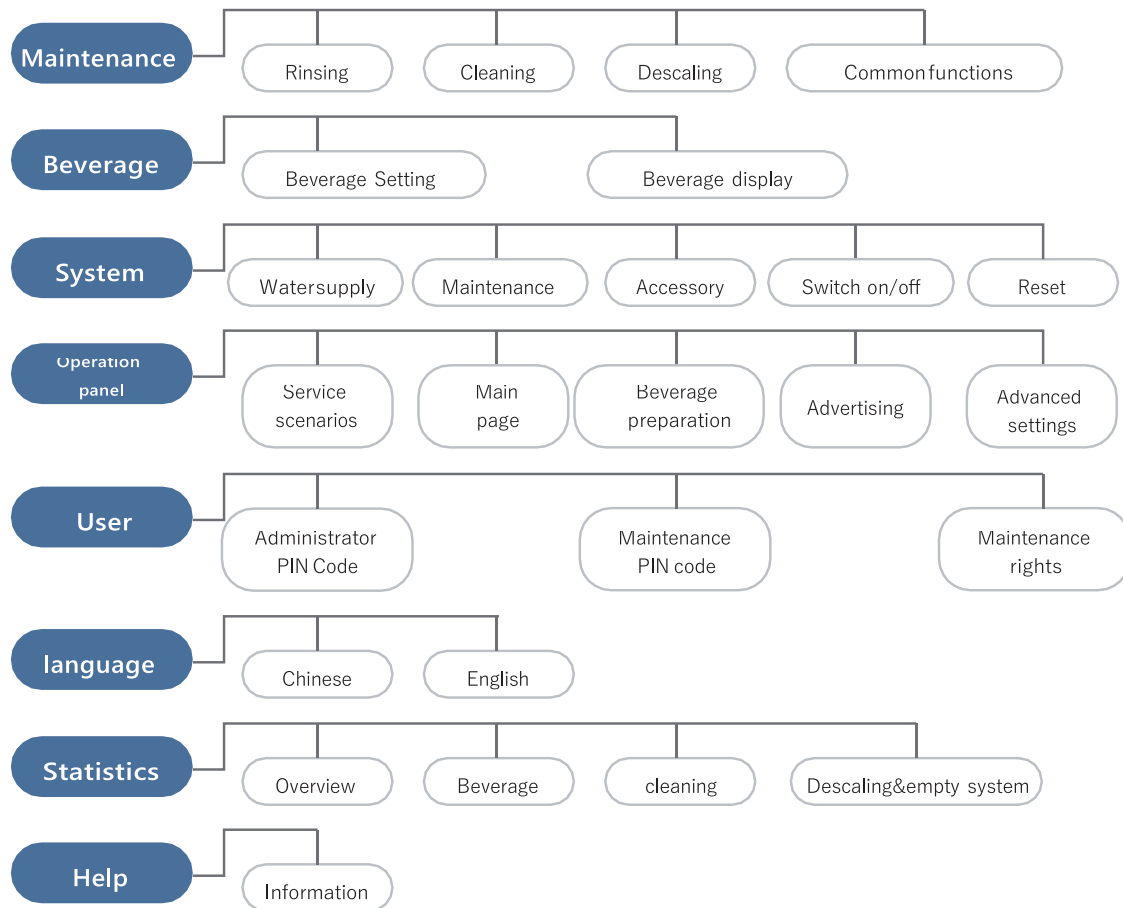

6.3 Maintenance

6.3.1 Overview of cleaning menu

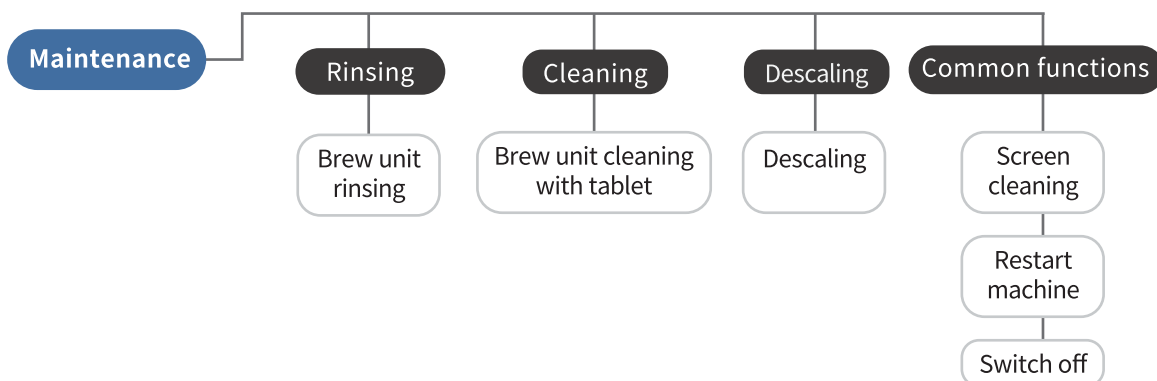

6.3.2 Rinsing

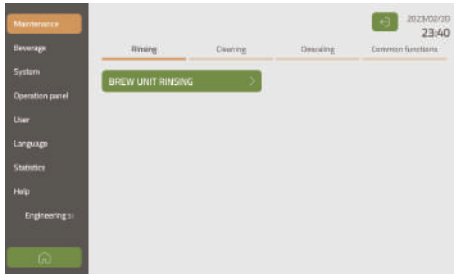

Brew unit rinsing
Immediately carry out hot rinsing of brewing system after tapping it.

6.3.3 Cleaning

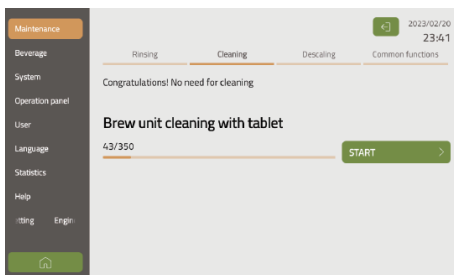

Cleaning brew unit
Immediately carry out tablets cleaning program of brew unit after tapping start, if the message of '**Brew unit cleaning with cleaning tablets**' appears on the screen. Cleaning tablets are needed in the process of cleaning. Total duration is approx. 10 minutes.

6.3.4 Descaling



Descaling powder is used in the process of descaling. Total duration is approx.45 minutes.

6.3.5 Common function

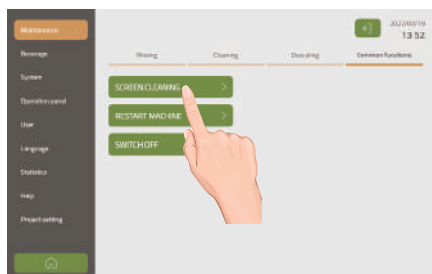

Screen cleaning
Machine will be locked for 15 seconds after tapping '**Screen cleaning**'. Now use a cloth to clean the surface of screen.

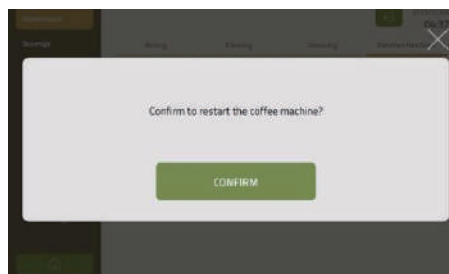

Restart machine
Restart machine system after tapping 'Restart'.

6.4 Beverage

6.4.1 Beverage setting overview

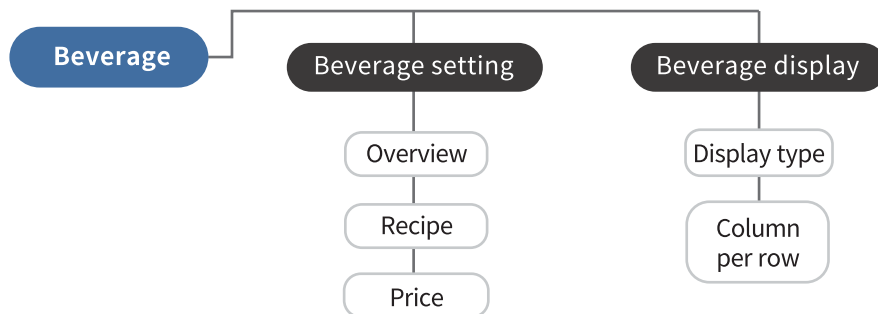

6.4.2 Beverage setting

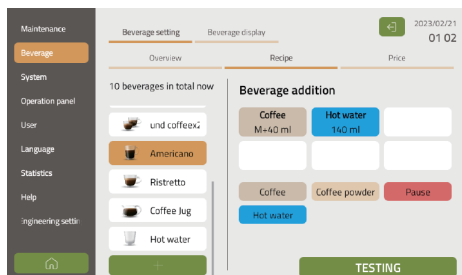

1. Change beverage icon

Change beverage icon after tapping edit icon. Image uploaded from USB stick can be used as beverage icon.

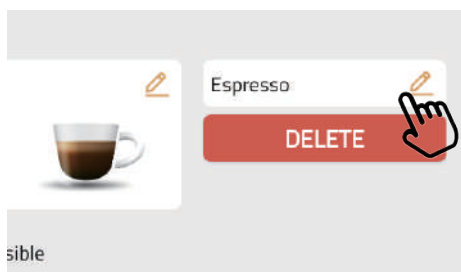

2. Change beverage name

Change beverage name after tapping edit icon. Beverage name can be customized by users using input method.



3. Beverage status

Select 'Active' can prepare this beverage. Select 'Inactive', the beverage will be locked and cannot be prepared.

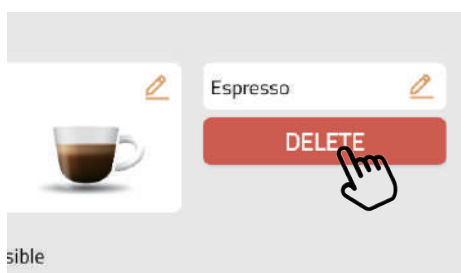

4. Delete the beverage

Tap 'Delete' key beneath beverage will delete the beverage from beverage list.

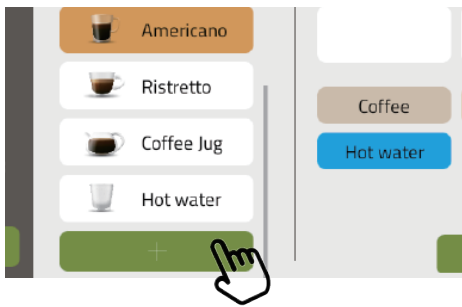

5. Add new beverage

Tap 'Add' that you can select new drink that you want to add from popup list. Change and define name and icon of new beverage after adding new drink into menu list.

Recipe setting

Take Americano for example, after touching latte beverage symbol you will be able to access to recipe page, beverage parameter setting modification is permitted.

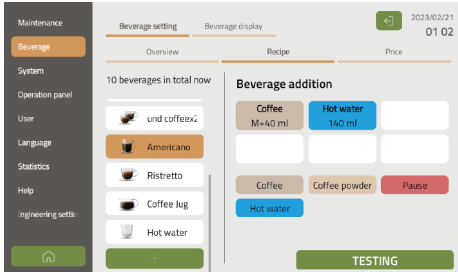

Check current recipe

The order from left to right is the sequential order of beverage flowing out: Milk foam-Hot milk-Coffee.

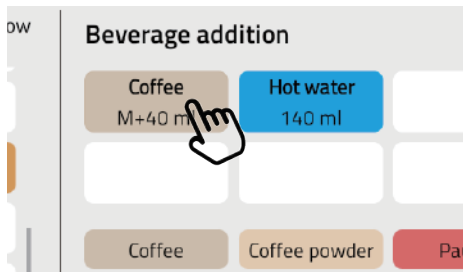

Change recipe order

press recipe icon(e.g. coffee) and dragging it to change its position.

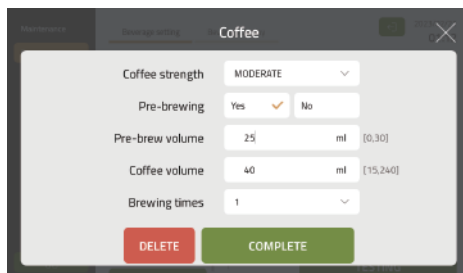

Change recipe parameters

Tap recipe, change recipe parameter is permitted. Specific settable value range needs to comply with limited condition of software.

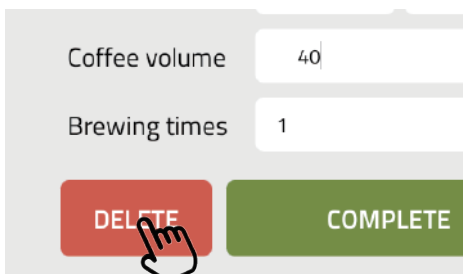

Delete recipe

Access to recipe page and tapping 'Delete' button.

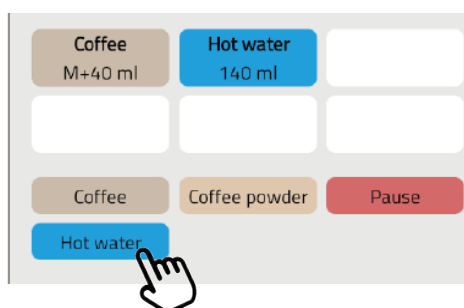

Add recipe

- 1.Factory additions list appears here.
The recipe will pop up to beverage recipe composition list automatically after tapping it.
- 2.The range of beverages addable recipe: 1~6.
- 3.Specific settable value range needs to comply with the limited conditions of software.
- 4.Every settable recipe parameter as shown the left image.

Addable recipe parameter

Coffee

Parameter	Value range	Remarks
Pre-brew volume	0~30ml	Default:25ml
Coffee volume	15~240ml	Default:150ml
Brewing times	1~4 times	Default:1

Coffee powder

Parameter	Value range	Remarks
Pre-brewing	Yes or no	Default: No
Coffee volume	15-240ml	Default:50ml

Hot water

Parameter	Value range	Remarks
Water volume	25~450ml	Default:100ml
Water temperature	High,Medium , Normal	Default: High

Pause

Parameter	Value range	Remarks
Time	1~20 seconds	Default: 5 seconds

Test

Tap ' **Test** ' to prepare the drink using the modified recipe after recipe setting is completed, and test if the drink can satisfy the expectation.

6.4.3 Beverage Display

Two modes of beverage display are available: grid layout and menu cards.

Grid layout

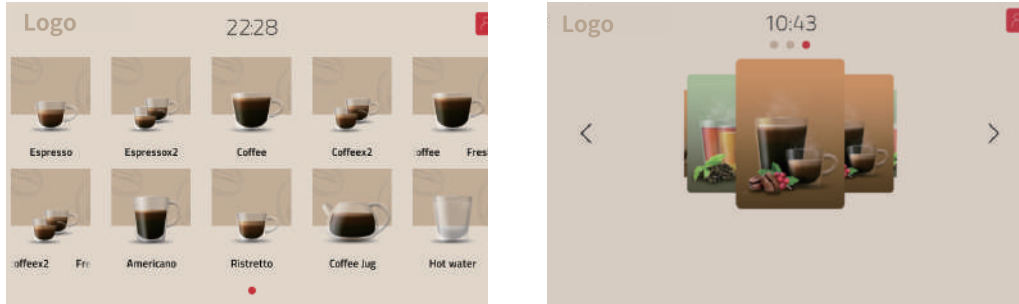

Grid layout parameter setting as follows:

Parameter	Value range(Standard/Self service)				Remarks
Column per	1x1	2x1 3x1	4x1 5x1 3x2	4x2 5x2	Default: 5×2

Parameter	Value range (Professional)			Remarks
Column per	2x1 3x2	3x3 2x2	4x3	Default: 4×3

Menu cards



Beverages in the beverage list can be sorted into different menu cards. Menu cards numbers: 2-7.

- 1.Touch the cover image of the menu card to replace it with a new one.New cover image can be selected from photo gallery and also can be loaded from USB stick;
- 2.Touch '**update the cover name**' can modify the cover name;
- 3.Touch second level, beverages in the beverage list can be selected and added into menu cards;
- 4.Effect of activating '**Display second level beverages in first page**' as following image.

6.5 System

6.5.1 Overview of system menu

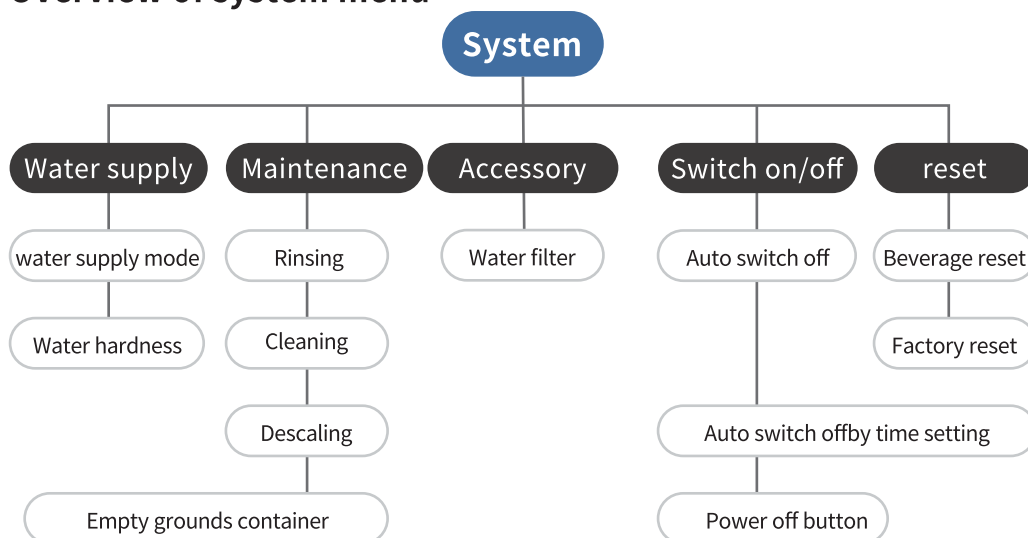

6.5.2 Water supply

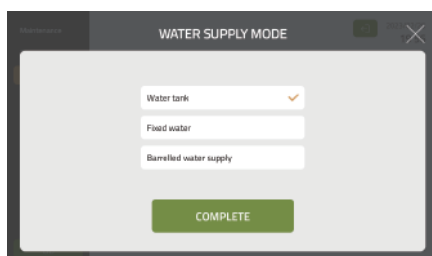

Water supply mode

Select corresponding water supply mode. Default setting is water tank supply.

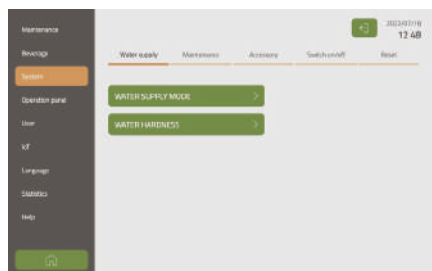

Water hardness

Setting water hardness value for the machine here. Default setting: 5 dh.

6.5.3 Maintenance parameter setting

Rinsing

Rinsing parameter setting as below:

Parameter	Set range	Remarks
Warm-up rinsing	30 minutes 1~4 hours	Default: 30 minutes
Brew unit auto rinsing	Off 5~20 minutes	Default:Off
Milk frother auto rinsing	Off 5~20 minutes	Default: 10 minutes

Cleaning

Parameter setting of brewing unit cleaning with tablets as below:

Parameter	Set range	Remarks
Brewing unit cleaning with tablets warning cups	≥0 cup	Default: 350 cups
Compulsory brew unit cleaning with tablets warning cups	≥0 cup	Default: 450 cups

Descaling

Water hardness, water flow and water filter installation or not, which determine the liter and time remaining before descaling. Parameter setting of descaling as below:

Parameter	Set range	Remarks
Descaling warning	≥0 liter	Default: 2500 liters
Forced descaling	≥0 liter	Default: 3600 liters

Empty grounds container

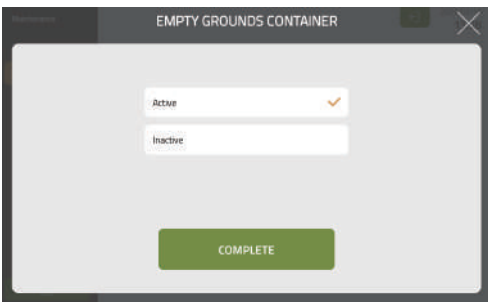

1. Select ' active ', ' empty grounds container ' will be displayed when the coffee grounds pcs reaches to 30 or the thicckness reaches to 400mm;
2. Select ' Inactive ', ' empty grounds container ' will be not displayed on the screen.

6.5.4 Accessories

Water filter

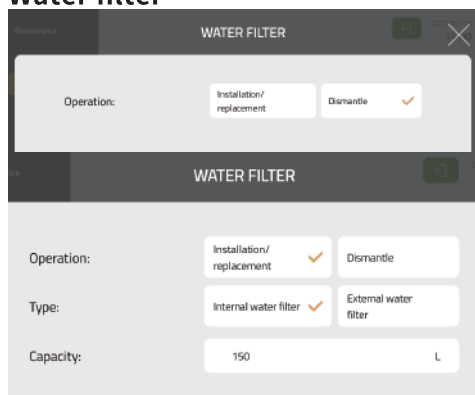

1. Select ' **Dismantle** ' if not install the water filter;
2. Select ' **Installation/Replacement** ' here if install or replace filter cartridge. Select the type of filter cartridge and input capacity is needed here.
3. Default setting: ' **Dismantle** '

6.5.5 Switch off

Auto switch off countdown

Setting the auto switch off countdown here, like auto switch off the machine in 8 hours.

Parameter	Set range	Remarks
Auto switch off countdown	30minutes, 1~24 hours Never switch off	Default: 4 hours

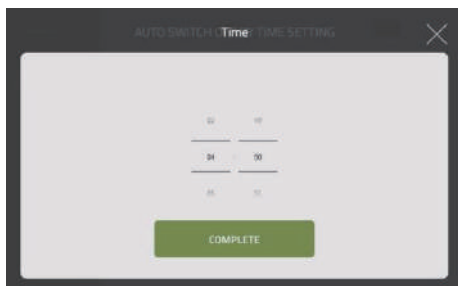

Auto switch off by time setting

Setting the time of auto switch off here, like 9 :15 am.



Power off button

1. Select ' Active ', press power button lasts 3 seconds to turn off the screen.
2. Select ' Inactive ', the function of screen power switch is disabled.

6.5.6 Reset

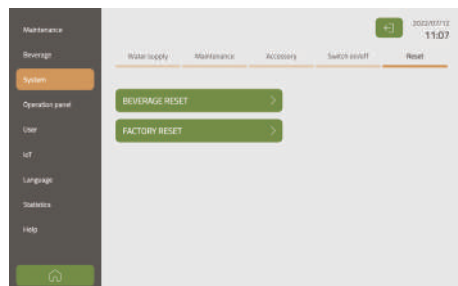

Beverage reset

Restore all relative parameter of beverage to factory default setting.

Factory reset

Restore all parameter of machine to factory default setting.

6.6 Operation panel

6.6.1 Service scenarios

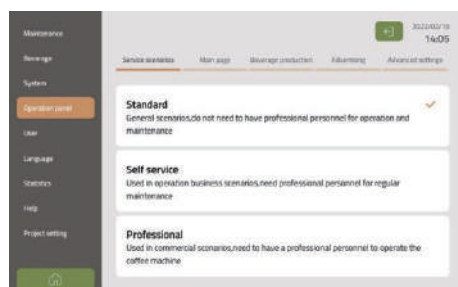

Select interface mode displayed on the screen. Specific introduction of each interface mode displayed on the screen see page 7 .

6.6.2 Main page

Member function

Option: Active Inactive



1. Select '**Active**', tap membership key in the upper-right corner of screen, then create member and favorite drinks list.
2. Select '**Inactive**', membership key is not displayed.

Serial number

Option: Active Inactive



1. Select '**Active**', machine serial number is displayed in the lower left corner of screen.
2. Select '**Inactive**', machine serial number is not displayed.

Service call

Option: Active Inactive

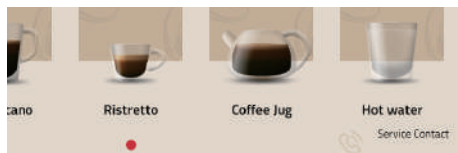

1. Select '**Active**', service call is displayed in the lower right corner of screen.
2. Select '**Inactive**', service call will not be displayed.

LOGO Change

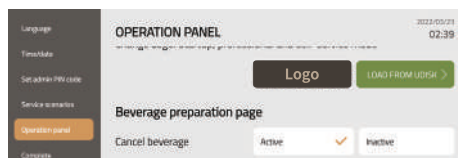

Touch edit key to change logo displayed on the screen. Load new Logo image from USB stick.



Backgrounds of LOGO image used in start-up page, professional mode and self-service mode are must be black.

6.6.3 Beverage Preparation

Cancel beverage

Option: Active Inactive



- 1.If select '**Active**' drink preparation can be canceled by touching '**stop**'.
- 2.Select '**Inactive**', '**stop**' will not be displayed.

Beverage adjustment

Option: Active Inactive

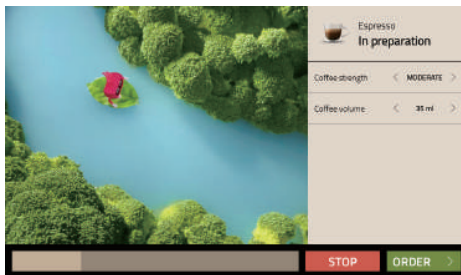

- 1.Select 'Active', drink recipes could be adjusted by touching left and right key when the beverage is in production.
- 2.Select 'Inactive', drink recipes could not be adjusted when the beverage is in production.

Volume display

Option: Active Inactive

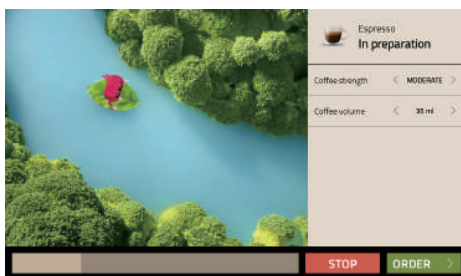

- 1.Select 'Active', drink recipes will be displayed when the beverage is in production.
- 2.Select 'Inactive', drink recipes will not be displayed when the beverage is in production.

Continue to order

Option: Active Inactive



- 1.Select 'Active', touch 'order' to select next drink.
- 2.Select 'Inactive', 'Order' will not be displayed.

6.6.4 Advertising

AD - Standby

Set advertisement videos when the machine is in standby. Advertising resources could be loaded from USB stick.

Parameter	Set range	Remarks
Waiting time	0~100 seconds	Default: 60 seconds
Cycle type	Infinite loop ; Exit automatically after playing	Default:Off
Single image-play time	0~100 seconds	Default: 10 seconds



Advertising setting is available here, videos and images used can be loaded from USB stick.

AD - Welcome

Set advertisement videos when the machine is started.

Parameter	Set range	Remarks
Single image play time	0~100 seconds	Default: 5seconds



Video requirements: MP4 format, proportion16:9, recommended resolution ratio1280x800, Video bitrate less than 3000kbps and 100M, image format: PNG, JPG, JPEG, recommended resolution ratio1280x800.

AD - Beverage in preparation

Set advertisement videos when the beverage is in preparation.

Parameter	Set range	Remarks
Single image play time	0~100 seconds	Default: 5seconds



Video requirements: MP4 format, proportion 4:3, recommended resolution ratio890x700, Video bitrate less than 3000kbps and 100M, image format: PNG, JPG, JPEG, recommended resolution ratio:890x700.

6.6.5 Advanced settings

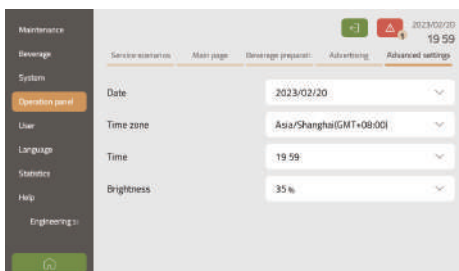

Date

Set local date

Time zone

Set local time zone

Time

Set local time

Brightness

Set brightness. Default: 60%

6.7 User



Different user rights can be assigned with corresponding PIN code.

6.7.1 Administrator PIN Code

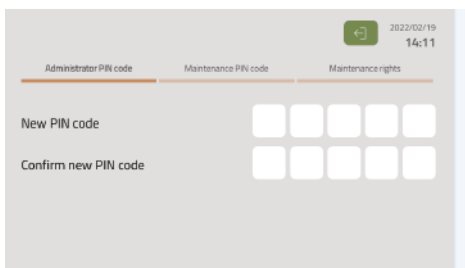

Set admin PIN code, which is formed from 5 digits. Input correct pin code can view all rights of menu.

6.7.2 Maintenance PIN code

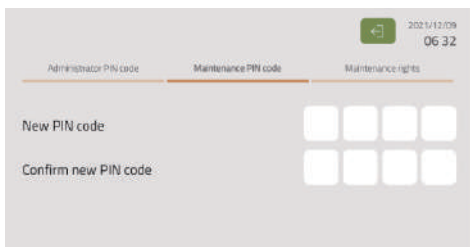

Set maintenance PIN code here, which is formed from 4 digits. Input correct pin code can view assigned maintenance rights.

6.7.3 Maintenance rights

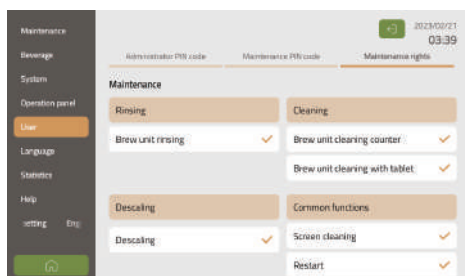

Setting specific rights for maintenance PIN code here.

6.8 Language



Display available languages here.
 Select language.
 Default language setting is English.

6.9 Statistics

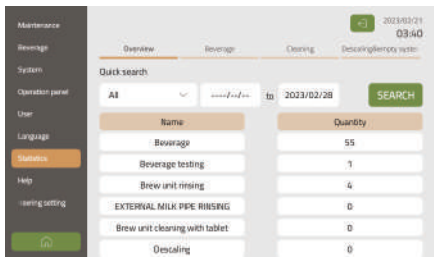

View the history records of various beverage preparation data, total drink numbers, care and maintain here.

6.9.1 Beverage

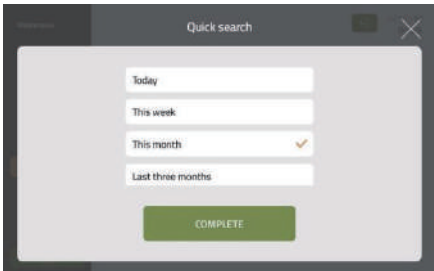

Quick search
 Data can be viewed by 1 week, 1 month, 3 months, current date, half year, one year. View the data of certain time can be customized. The data could be presented in two ways: tables and graphs.

6.9.2 Cleaning



Specific time records of various cleaning items can be viewed here. Including the start time, ending time and duration time of cleaning items.

6.9.3 Descaling/empty system



History records of descaling and emptying water system can be viewed here.

6.10 Help

About View Machine Information



Information regarding this machine could be viewed here including. Ctr version (PCB software) HMI version (Screen software) Android system version Calibration file version.

Serial number of machine IMEI information of machine Available storage space of screen.

Upgrade software via USB stick

Program of machine can be upgraded by USB stick



Software program upgrade needs to be instructed by professional technician, contact customer service personnel for help

7. Cleaning and maintenance

The perfect coffee experience depends on a perfectly cleaned coffee machine. Clean your coffee machine at least once a day and more frequently if necessary. Clean the machine immediately if you find that it is dirty or clogged.

7.1 Cleaning intervals overview

Cleaning intervals	Operation	Type
Daily (or needed)	Brew unit rinsing	automatic or manual
	Empty drip tray	manual
	Empty grounds container	manual
	Clean the screen	manual
Weekly	Clean the brew unit	manual
	Clean the water tank	manual
If presents	Brew unit cleaning	When the screen shows a message
	Descaling	When the screen shows a message
	Filter change	When the screen shows a message

7.2 Parts preparation

Parts	Usage
Cleaning tablet	Brew unit cleaning with tablet
Milk system cleaning agents	Milk system cleaning
Descaling powder	Descaling
key	Adjust grinding level
Milk hose brush	Clean milk hose manually
Damp cloth	Clean bean hopper, screen, machine surface

7.3 Daily cleaning

7.3.1 Brew unit rinsing

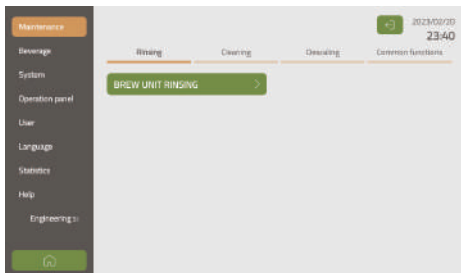

1. Every automatic rinsing intervals could be set in Menu / Maintenance setting, then rinsing will be processed automatically after reaching the setting condition.



2. Immediately rinse can be selected manually. Enter '**Maintenance/Rinsing**' menu, and touching each rinsing option can rinse at once.



Hot water will be dispensed from coffee spout during rinsing, be careful to avoid scalding.

7.3.2 Empty grounds container

Empty grounds container (at least once per day).



1. Remove grounds container



2. Pour out the coffee grounds



3. Clean it thoroughly with fresh water



4. Dry and place the grounds container back

7.3.3 Empty drip tray

The drip tray is below the grounds container. Clean the drip tray as needed (at least once per day).



1. Remove the drip tray



2. Pour out waste water



3. Clean it thoroughly with fresh water



4. Dry and place the drip tray back



Must clean the two metal plates in front of the drip tray and keep them dry, otherwise, **'empty drip tray'** will be misreported.

7.3.4 Clean the screen

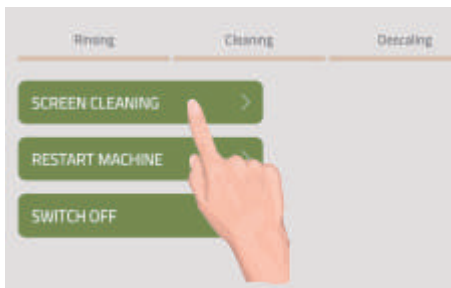

Enter '**Maintenance/Common functions**'. Select '**SCREEN CLEANING**' to start a 15- second countdown. Now screen can be wiped by a dry cloth.

7.4 Weekly cleaning

7.4.2 Clean the brew unit with the brush

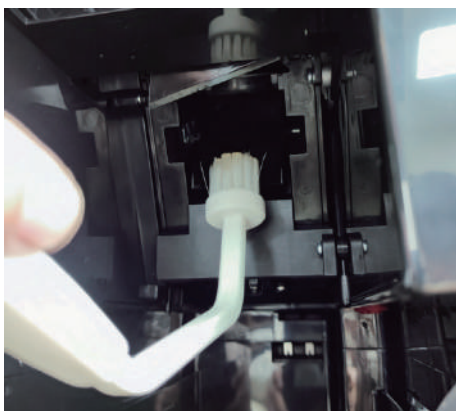

1. Brew unit will be clogged when coffee beans are grinded too fine.

Suggest using brush clean brew unit per week.

7.5 Brew unit cleaning if presents

A message ' **Brew unit cleaning with tablet** ' will appear on the screen when the coffee system need to be cleaned with a tablet.Total duration is approx. 10 minutes.

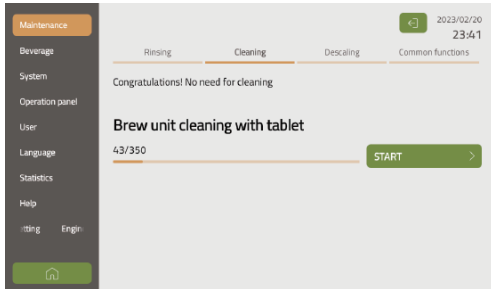

1. Access to ' **Maintenance/Cleaning** ' menu

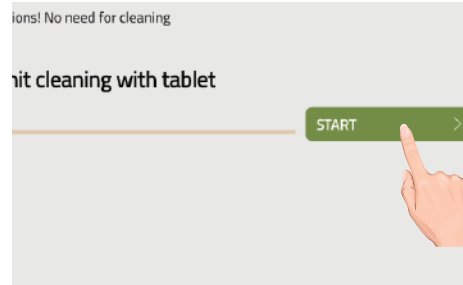

2.Touch ' **START** ' button

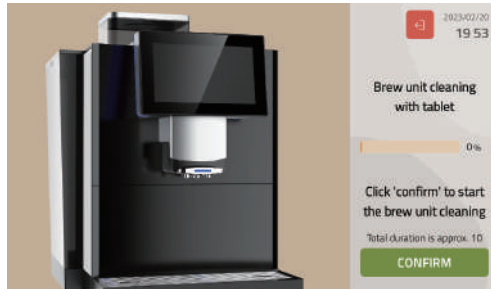

3. Touch ' **Confirm** ' to start the cleaning

4. Perform every step according to the message displayed on the screen



If brew unit cleaning with tablets is not performed in time,the screen will be locked after reaching the preset compulsory cleaning intervals, and the machine cannot continue to use until cleaning process has been completed.

7.7 Descaling if presents

The water hardness, water flow, and whether a water filter is used determine the schedule for descaling. Descaling time is calculated by the E30 and displayed.

7.7.1 Descaling



If descaling is not be carried out in time, the screen of machine will be locked after reaching the preset compulsory descaling, and the machine cannot continue to use until descaling process has been completed.

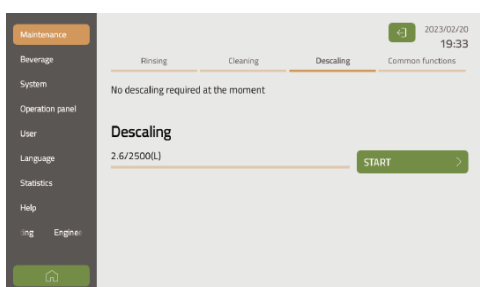

1. Access to 'Maintenance/Cleaning' menu

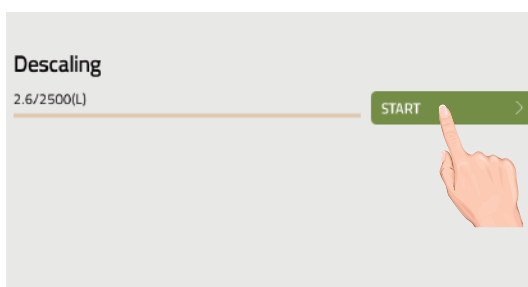

2. Touch 'START' button



3. Touch 'Confirm' to start the cleaning

4. Perform every step according to the message displayed on the screen



During cleaning and descaling, hot cleaning solution or descaling solution flows out of the spout. So never reach under the spouts while descaling.

8. Messages and explanation

8.1 Operational messages

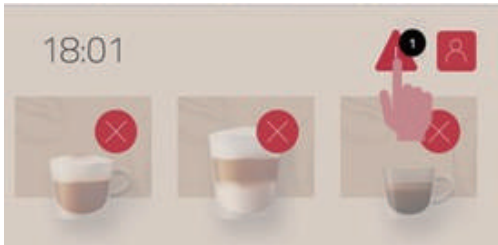

When an error occurs, the machine displays an error message, which is indicated by a red triangle in the upper-right corner of the operator panel. Tap this symbol to obtain more information.

Information	Possible solutions
Place the water tank	Check whether the water tank is installed correctly or place it back
Fill water tank	Fill water tank
Place drip tray	Place drip tray back
Empty drip tray	Empty drip tray
Empty grounds container	Empty grounds container
The coffee system empty	Check the steam circuit
The steam system empty	Check the steam circuit
Multi-way valve warning	Check the steam multi-way valve
Brew unit reset	Check the brew unit
Software error	Restart the machine
Serial port failure, please check the serial port connection	Check the main PCB
CTR error	Flash the software

8.2 Error message

The error message will appear automatically when the entire system is affected by an error. Restart machine if serious problems appeared.

1. Switch off the machine by main switch when restart the machine
2. Please contact service technician if the machine cannot be started or if you are unable to fix error

Error code	Error description	Possible solutions
E2	NTC sensor detect if thermoblock (coffee) temp higher than 105 °C	Restart the machine
E3	NTC sensor detect if thermoblock (steam) temp higher than 185 °C	Restart the machine
E43	The brew unit gear does not run for correct cycles	Check the brew unit
E33	No communication between CTR and HMI	Check the main PCB
E1	PCBA error	Restart the machine

9. Decommissioning

9.1 Preparing for decommissioning

1. Clean the machine by using all cleaning and rinsing function.
2. Cleaning after empty bean hopper.
3. Clean beverage spout and milk pipe manually.
4. Clean brew unit with the brush.
5. Clean drip tray and grounds container etc.

9.2 Short-term decommissioning (within one month)

1. Empty water circuit (Have your coffee machine drained by your service technician).
2. Disconnect the machine from the power supply.
3. Shutting off the water supply.
4. Switch off the add-on units and disconnect them from the power supply.

9.3 Long-term decommissioning (over one month)

Some components may no longer function as they should if they have been stored or unused for long periods.

Coffee machine must be maintained, installed, and cleaned before preparing any drinks.

1. Have your coffee machine drained by your service technician.
2. Remedial maintenance may be required when commissioning the machine again if it has been stored in excess of 6 month. Please contact service personnel for support.

10. Transport and storage

10.1 Transport

Protect the machine from mechanical damage and adverse environmental conditions during transport and storage.

1. Protect the machine from falling or tipping over.
2. Restore external packaging of machine well to use in transportation.
3. In order to avoid the damage to machine, water in the coffee machine must be emptied before transportation.
4. After the completion of emptying water circuit, dry the machine, inside and out.



Empty water circuit must be performed by professional technician, please contact service personnel for support



If the program of emptying water circuit is performed, coffee system needs to re-perform the program that has been carried out in the first time use when using the machine again

10.2 Storage

Storage conditions must be fulfilled:

1. Permissible temperatures: -10 to +50°C
2. If the machine has not been drained and emptied completely, it must not be stored at sub-zero temperatures
3. Set the machine up in a standing position
4. Machine system emptied
5. Machine and accessories packaged, preferably in their original packaging.

10.3 Recommissioning after prolonged periods of storage or non-use

Coffee machine may no longer function if they have been stored or unused for periods in excess of 6 months. Contact your service team for information regarding restoring and recommissioning your machine.

11. Disposal

When disposal of coffee machine, some internal spare parts are still worth using again, Pay attention to deal with old parts in an environmentally neutral way.

1. Beans can be composted.
2. Observe the information on the label when disposing of any unused cleaning agent.
3. Dispose of the fluids from the cleaning container or the drip tray in the wastewater system.



Dispose of electronic parts separately



Dispose of plastic parts in accordance with their marking

